

# Tyler/Union

## MECHANICAL JOINT GASKETS ANSI/AWWA C111/A21.11

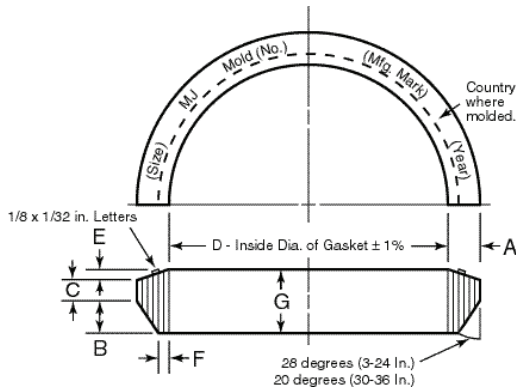

Pipe Size	Pipe OD	A ± 0.01"	B	C	D ±1%	E ± 0.01%	F ± 0.01"	G ± 0.02"
2*	2.50	.48	.62	.31	2.48	.12	.15	1.05
3	3.96	.48	.62	.31	3.86	.12	.15	1.05
4	4.80	.62	.75	.31	4.68	.16	.22	1.22
6	6.90	.62	.75	.31	6.73	.16	.22	1.22
8	9.05	.62	.75	.31	8.85	.16	.22	1.22
10	11.10	.62	.75	.31	10.87	.16	.22	1.22
12	13.20	.62	.75	.31	12.95	.16	.22	1.22
14	15.30	.62	.75	.31	14.99	.16	.22	1.22
16	17.40	.62	.75	.31	17.07	.16	.22	1.22
18	19.50	.62	.75	.31	19.13	.16	.22	1.22
20	21.60	.62	.75	.31	21.20	.16	.22	1.22
24	25.80	.62	.75	.31	25.34	.16	.22	1.22
30	32.00	.73	1.00	.38	31.47	.16	.37	1.54
36	38.30	.73	1.00	.38	37.67	.16	.37	1.54
42	44.50	.73	1.00	.38	43.78	.16	.37	1.54
48	50.80	.73	1.00	.38	49.98	.16	.37	1.54

Not included in AWWA C111. Manufacturer's Standard.

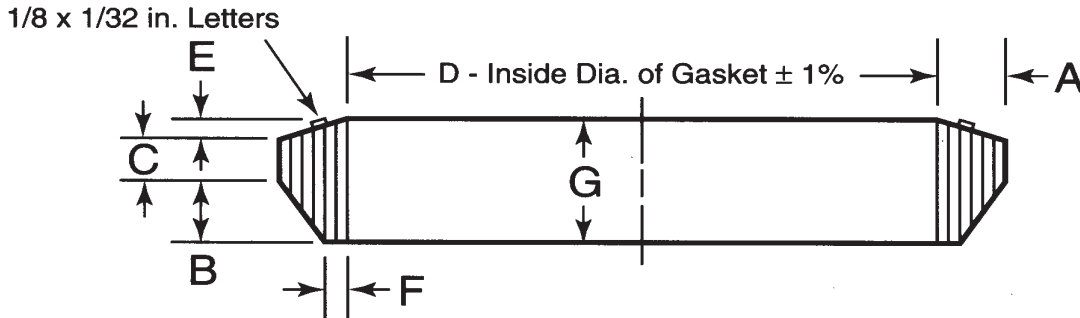

Mechanical Joint Transition Gasket Dimensions in Inches

Pipe Size	A ± 0.01"	B	C	D ±1%	E	F ± 0.01"	G ± 0.02"
3	.70	.62	.31	3.45	.16	.37	1.11
4	.77	.75	.31	4.43	.16	.37	1.26
6	.76	.75	.31	6.53	.16	.36	1.25
8	.82	.75	.31	8.50	.16	.42	1.27
10	.79	.75	.31	10.59	.16	.39	1.26
12	.84	.75	.31	12.56	.16	.44	1.28